

EMC Antenna Calibration Using the Standard Radiating Dipole Source

BRUCE ARCHAMBEAULT, SETH Corporation and
ROBERT SMITH, Naval Air Warfare Center

INTRODUCTION

EMC measurements require the use of a number of different instruments to determine the equipment under test's (EUT) compliance with regulatory standards. Engineers and technicians can not make accurate measurements with spectrum analyzers that are not calibrated. Great care and precision is used to calibrate spectrum analyzers and cables to antennas. However, depending on the type of measurement facility, the calibration of the antennas themselves can range from almost accurate to incorrect.

This article describes EMC measurement errors caused by improper calibration of antennas. Real-world measurements show the magnitude of the error when using only the manufacturer's calibration data. When a standard radiating dipole source is used to calibrate the antennas, the results from the standard antennas become much better. This significant improvement is due to the calibration of the antennas in the environment in which they will be used.

STANDARD ANTENNA CALIBRATION

The technique used to calibrate an antenna is very important. Typically, manufacturers provide antenna correction factors based upon a far-field source (without any conducting ground planes). Often these supplied

**Careful calibration
of all antennas is
important to insure
consistency
between test
laboratories and
various antennas.**

calibration factors are classified as typical, since the specific antenna factors are not determined for every antenna manufactured. Some manufacturers consider their calibration procedures secret. They strongly discourage visits to observe an antenna calibration, and so the true quality of the calibration ranges (as described) should be seriously questioned.

However, the real problem is more serious. Test sites usually use the manufacturer's published antenna factors to convert from the voltage reading at the spectrum analyzer's input to the electric field strength. If the calibration factors are not determined under the same measurement conditions as are used to characterize the EUT, then those calibration factors are wrong. Typically, calibration factors are determined for a far-field open environment. This environment is close to a fully anechoic room (at high frequencies where the far-field assumptions are correct), but it is quite different from an Open Area Test Site (OATS) used for FCC testing

or a shielded room environment used for TEMPEST and MIL-STD EMC testing. Almost the only thing that can be said about far-field antenna factors when the testing is done in a shielded room is that they are inaccurate and not repeatable. The metal walls, floor and ceiling are all too close to the antenna and interact in unpredictable ways.

For years arguments have been made in the literature, both for and against testing in shielded rooms. This article certainly will not presume to settle those arguments. The bottom line is that shielded room testing will continue for the foreseeable future. The question should be: "What can be done to make this testing as accurate and as repeatable as possible?"

THE CURRENT STATE OF AFFAIRS

The antenna factor is assumed to accurately convert the voltage at the receiver (or spectrum analyzer) to the true value of the electric field at the point in space where the antenna is located. Whether the electric field at that point is truly due to only the EUT, or is some combination of the EUT and the shielded room's walls is not part of this discussion. Therefore, although different antennas might be used to cover the same frequency range, the proper electric field will be determined since the antenna

Continued on page 190

factors will be different for each antenna.

As part of this effort to achieve accurate results, a dipole source antenna was set up at the Navy's EMI laboratory at Patuxent River, MD. Figure 1 shows the test setup geometry. Three dif-

ferent antennas were used to measure the field created from this source over a frequency range of 10 MHz to 600 MHz. The receive antenna position in the shielded room, generator level, etc. were all maintained constant throughout the test. Fig-

ure 2 shows the reported electric field results for the different antennas. As can be seen, the difference in the field levels varied significantly. The total deviation is plotted in Figure 3 and shows a deviation as much as 20 dB. From this data, it appears that the same EUT might be able to pass or fail a MIL-STD test depending upon which antenna was used. Clearly this is not acceptable.

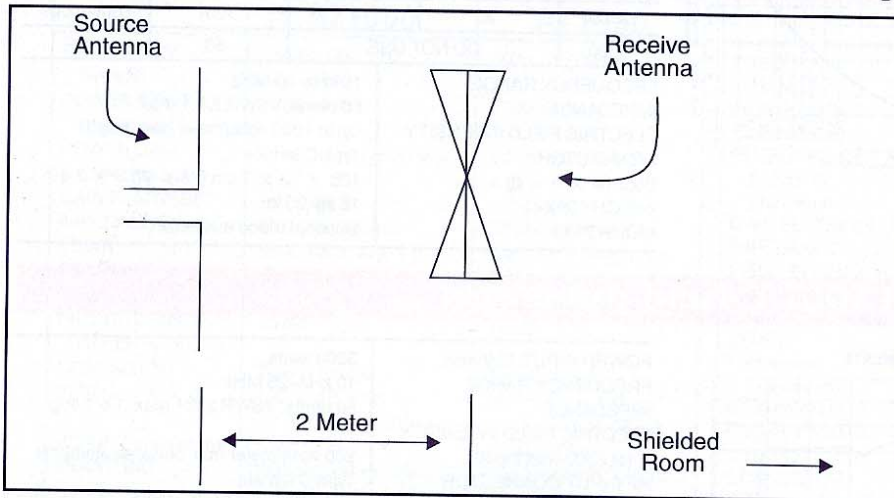

Figure 1. Initial Antenna Measurement Setup.

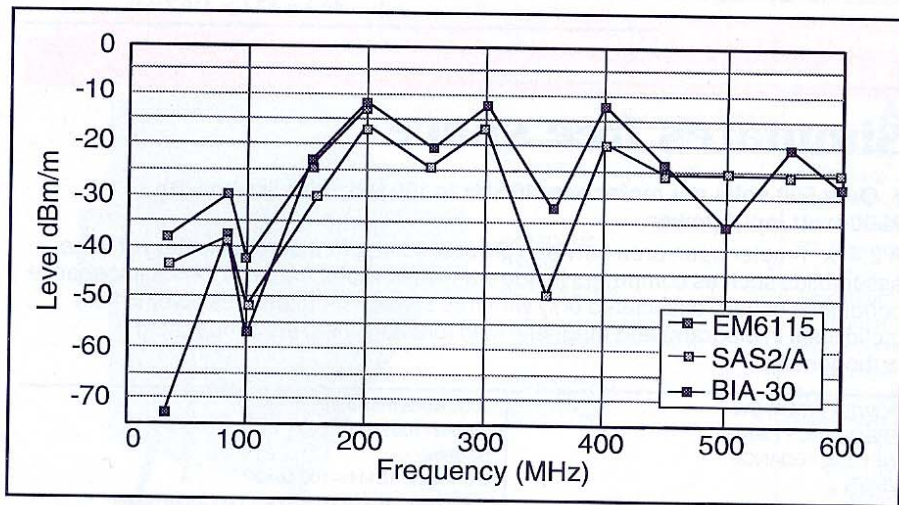

Figure 2. Assessment of Three Antennas Measuring the Same Signals in a MIL-STD-461 Laboratory Shielded Room Using Antenna Factors Provided by Respective Vendors.

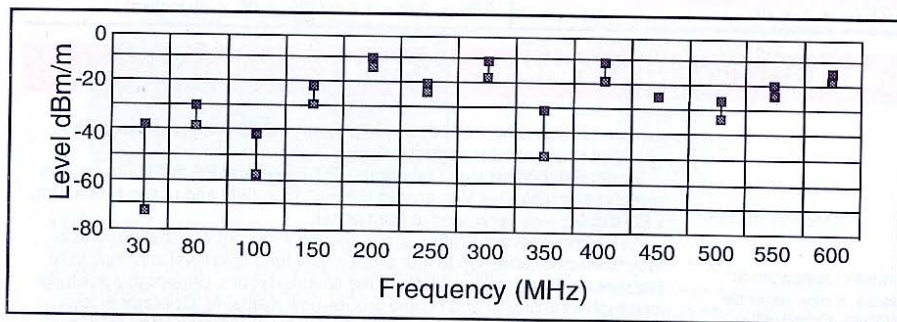

Figure 3. Minimum/Maximum Readings from Three Antennas Measuring the Same Signals in a MIL-STD-461 Laboratory Shielded Room Using Antenna Factors Provided.

SITE CORRECTION FACTORS

As mentioned earlier, the cause of this excessive deviation is due to the incorrect calibration factors. The antenna manufacturers cannot predict every possible use for their antennas, so they provide the antenna factors for the far-field open-space environment. The antennas really need to be calibrated in the environment where they will be used.

Research efforts have turned to how to perform this calibration in a shielded room. Obviously, a standard source is needed to provide the predictable electric fields at the desired distance. The source must be very repeatable so that the same electric field can be created whenever desired. The source must be physically small so that it will look as much like a point source as possible, and so its physical size will not be a factor during this calibration. Also the source should be physically repeatable so that once the source is placed in position, there will be no effect on coax cables, etc.

A standard radiating sphere is used to provide correction factors to the manufacturer's antenna factors. The test setup is shown in Figure 4. The standard radiating sphere is configured to provide a constant gap voltage at all frequencies, and the test is repeated for all antennas. The combination of the original antenna factors and the new correction factors creates the new

antenna calibration factor for the shielded room environment shown in Figure 1.

FINAL RESULTS

The initial tests with an unknown dipole source are repeated, using both the manufacturer's antenna factors and the determined site correction fac-

tors. The agreement between the various antennas is now quite good, as can be seen in Figure 5. The deviation between the various antennas is shown in Figure 6. The maximum deviation is now reduced to 1 to 2 dB, a significant improvement over the initial uncertainty.

SUMMARY

Careful calibration of all antennas is important to insure consistency between test laboratories and various antennas. Without such calibration it is possible to allow the same EUT to pass or fail the MIL-STD test limits, depending upon which antennas are used to make the measurements. However, once the antenna calibration is performed for the shielded room (or whatever environment is used) this repeatability and consistency issue is resolved.

This article has shown the importance of properly calibrating antennas when they are used in any environment other than an open-space far-field environment. Using the manufacturer's calibration factors (determined for the open-space far-field case) significantly increases the measurement uncertainty unless a correction factor for the true test environment is also used. This article has also shown the usefulness of a standard radiating source as the calibration antenna.

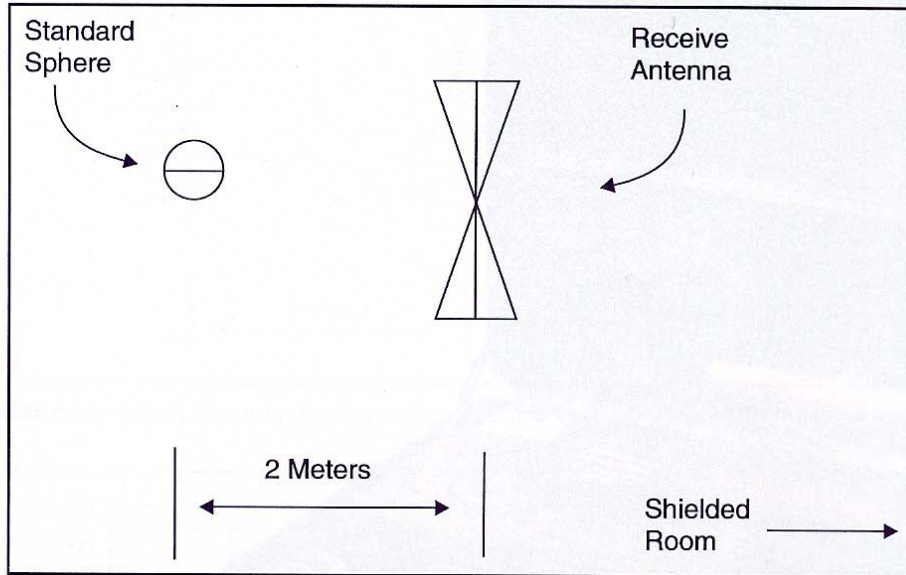

Figure 4. Spherical Radiating Standard Setup for Antenna Calibration.

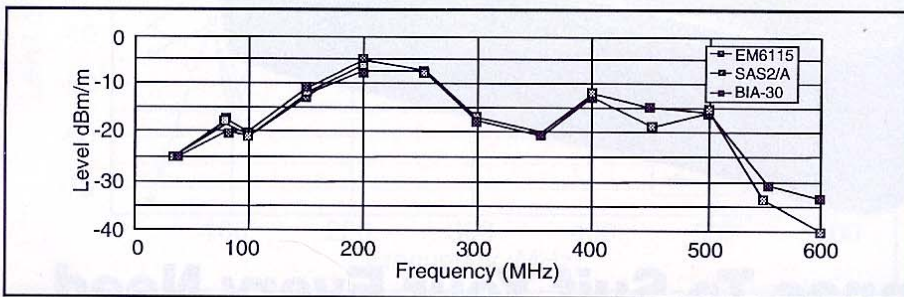

Figure 5. Assessment of Three Antennas Measuring the Same Signals in a MIL-STD-461 Laboratory Shielded Room Using Spherical Radiating Standard Derived Antenna Factors.

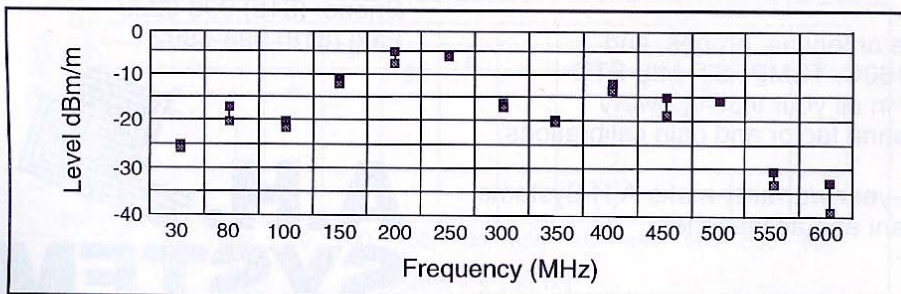

Figure 6. Minimum/Maximum Readings from Three Antennas Measuring the Same Signals in a MIL-STD-461 Laboratory Shielded Room Using Spherical Radiating Standard Derived Antenna Factors.

BRUCE ARCHAMBEAULT currently works for SETH Corporation developing new EMI modeling tools for industry. Bruce has been working in EMI modeling for over five years and has been in the EMI/TEMPEST business as a test and design engineer for over fifteen years. Bruce is currently completing his Ph.D. in electromagnetics, specializing in EM modeling. (603) 623-6565.

ROBERT SMITH is an electromagnetic interference contractor at the Naval Air Warfare Center in Patuxent River, MD. Mr. Smith's work in the MIL-STD-461 EMI Laboratory is focused on improving measurement techniques in shielded rooms. His previous experience as an electronic warfare specialist adds practical knowledge to EMI problems. Mr. Smith can be reached at PAX River. (301) 826-4791, ext. 157.